

Product Guide Catalogue Produits

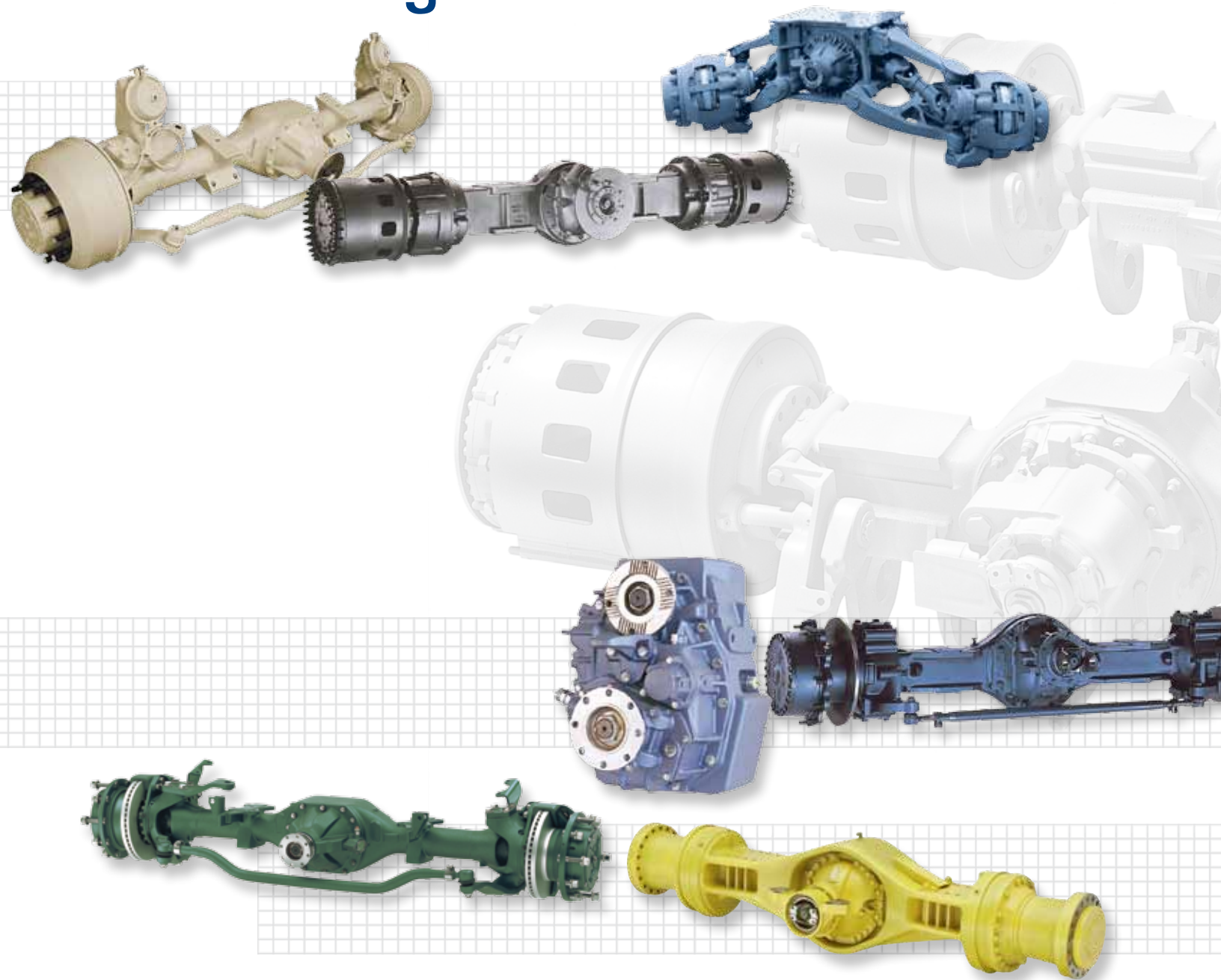

TABLE OF CONTENTS

Axles

Planetary Axle Model Designations.....	2
Planetary Axle Carrier Ratios	10
Independent Suspension Axle Systems.....	12
Planetary Steer Axles.....	14
Planetary Rigid Axles	18
Planetary Tandem Axles.....	26
Planetary Steer Tandem Axles	28
Planetary Tridem Axles.....	28
Portal Axles	28
T/A Series Axles.....	30
Jack Axles	30
Non-Drive Steer Axles.....	30

Transfer Cases

Two-Speed.....	32
Single-Speed	32

Brakes

Hydraulic Dry Disc Brakes	34
Park Brakes.....	34
Hydraulic Wet Disc Brakes.....	36
Drum Brakes	38

AXLES

Planetary Axle Model Designations

Single Planetary Axles

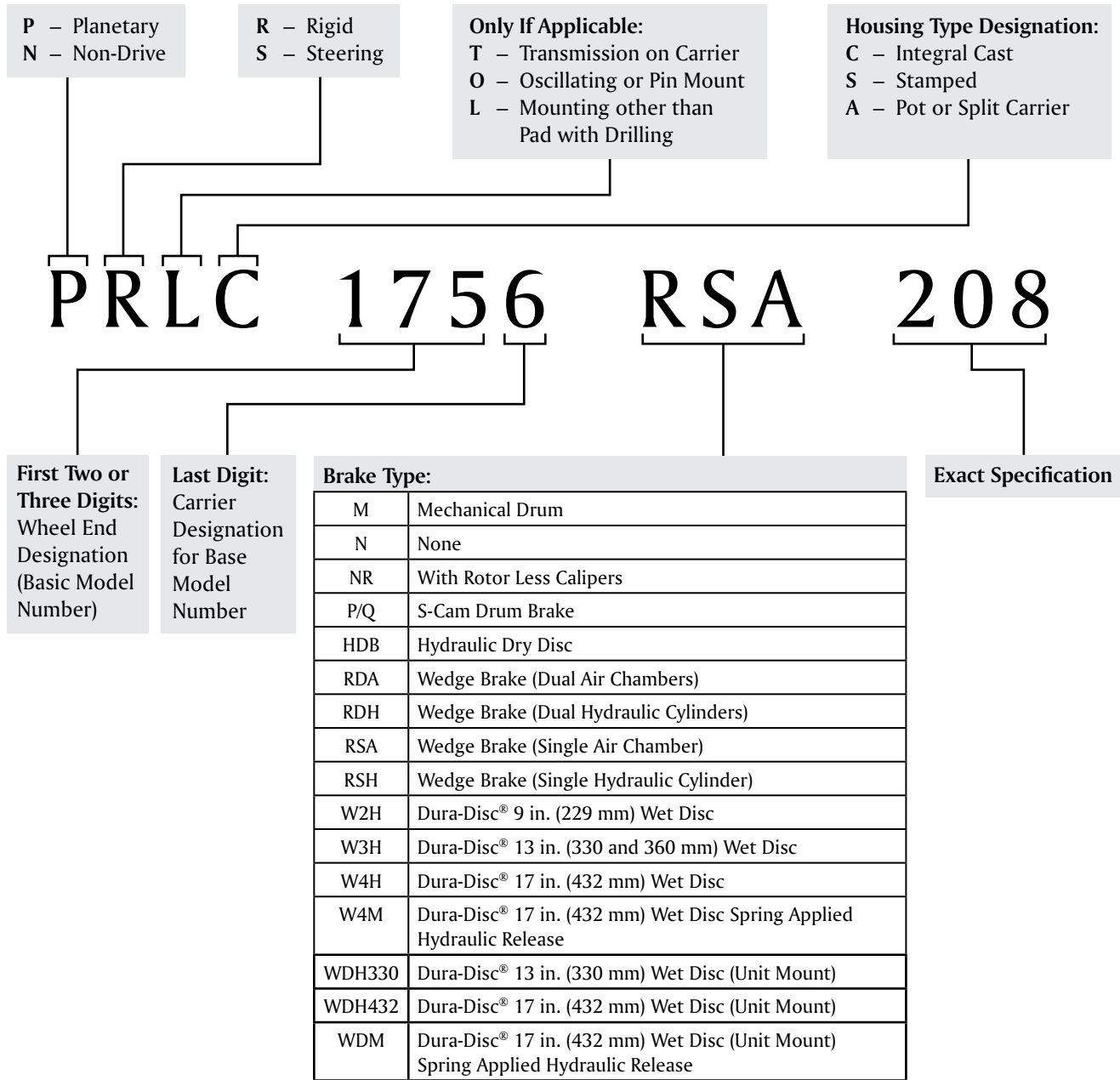

Examples:
PRC673P238
PSC822HDB218
PRLC1756P203

Planetary Axle Model Designations

Tandem or Tridem Axles

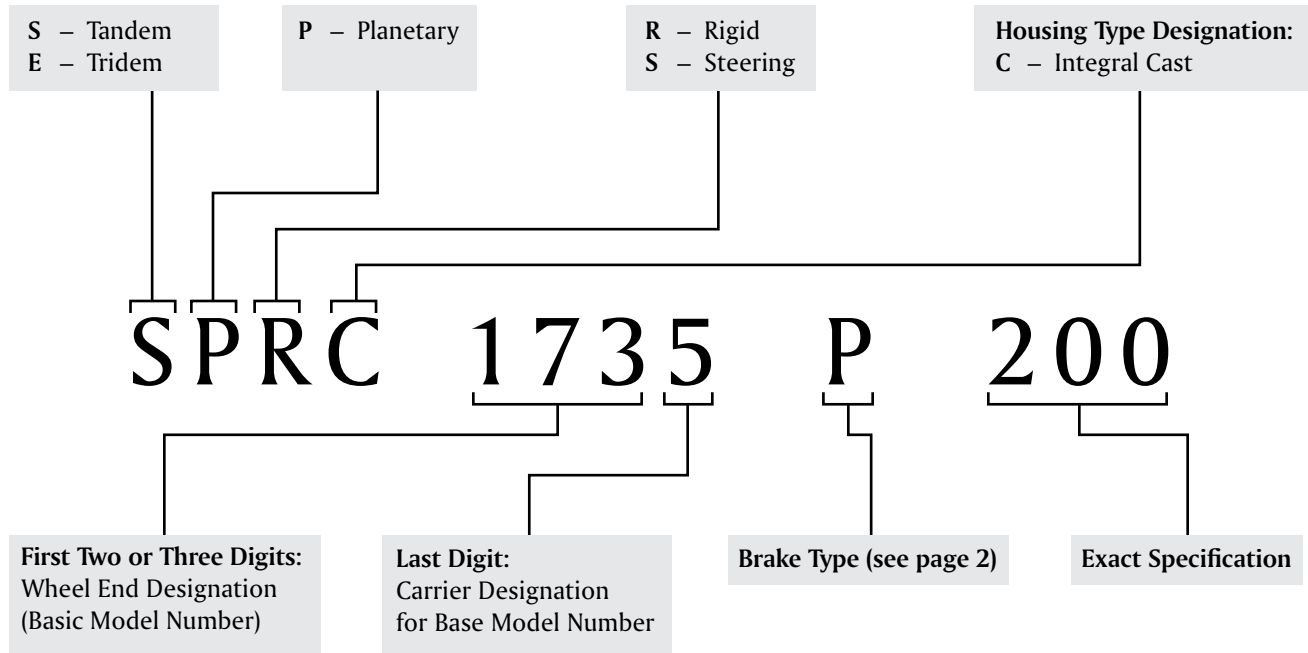

Examples:
 SPRC 1735 P 200
 (Tandem Set)

AXLES

Planetary Axle Model Designations

Tandem or Tridem Axles – Individual Axles

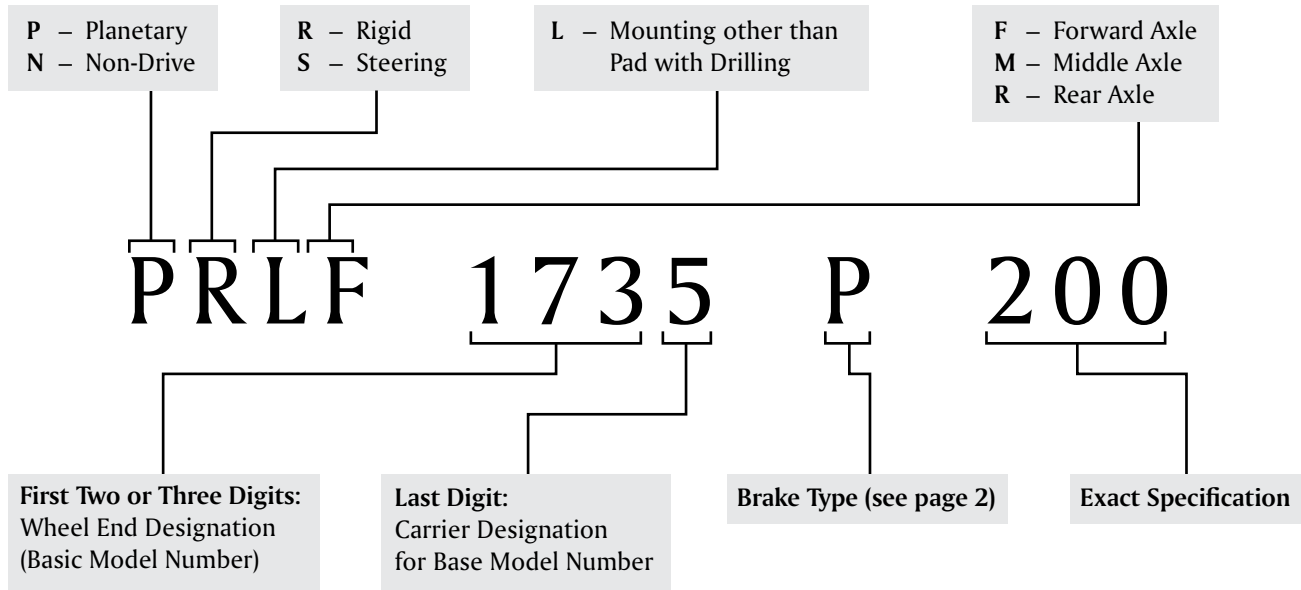

Examples:

PRLF 1735 P 200 (Forward Tandem Axle)
PRLR 1735 P 200 (Rear Tandem Axle)

PRLF 1735 P 200 (Forward Tridem Axle)
PRLM 1735 P 200 (Middle Tridem Axle)

PRLR 1735 P 200 (Rear Tridem Axle)

Planetary Axle Model Designations

Single, Tandem or Tridem Axles – Individual Axles

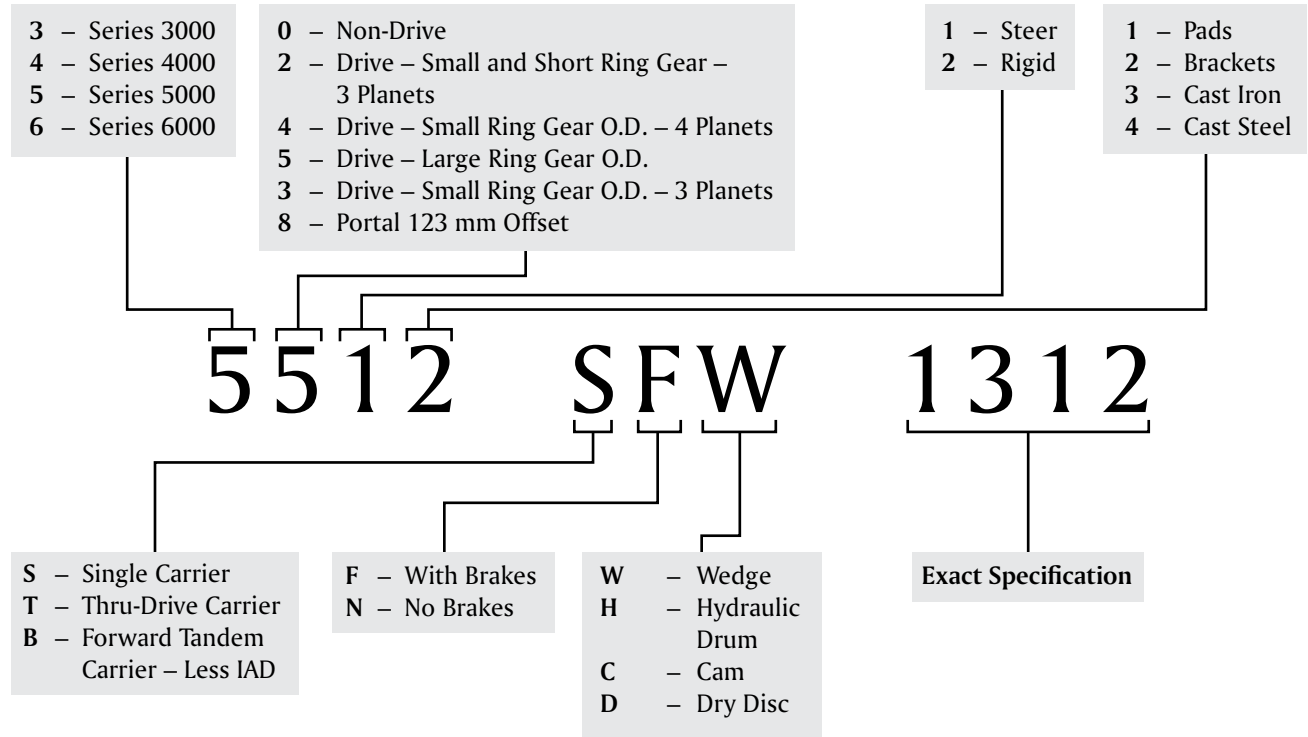

Examples:

5521 TFW (Forward Tandem Axle)
 5521 SFW (Rear Tandem Axle)

AXLES

Planetary Axle Model Designations

Independent Suspension Axle System

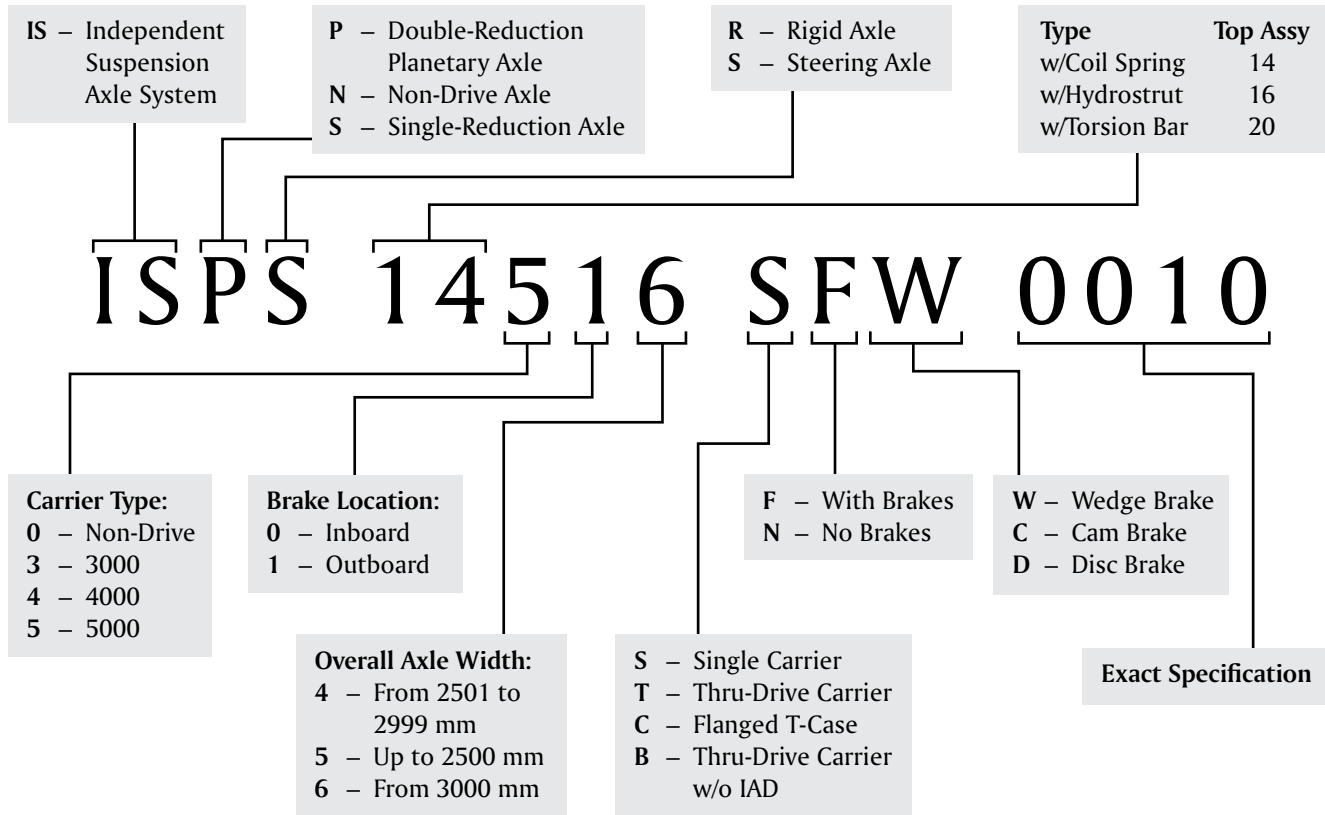

Planetary Axle Model Designations

Differential Carrier and Housing Assembly

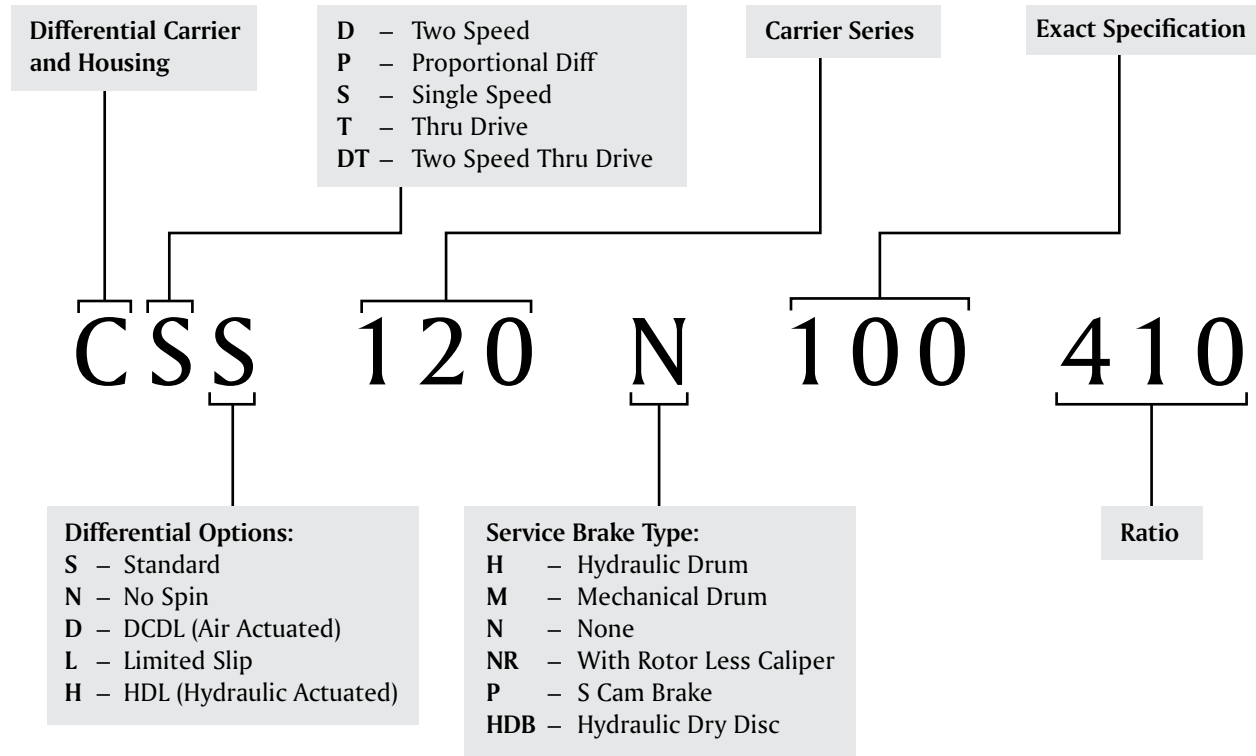

Examples:

CSS 5000 NR 100 225

CSD 120 N 100 410

AXLES

Planetary Axle Model Designations

Wheelend Module

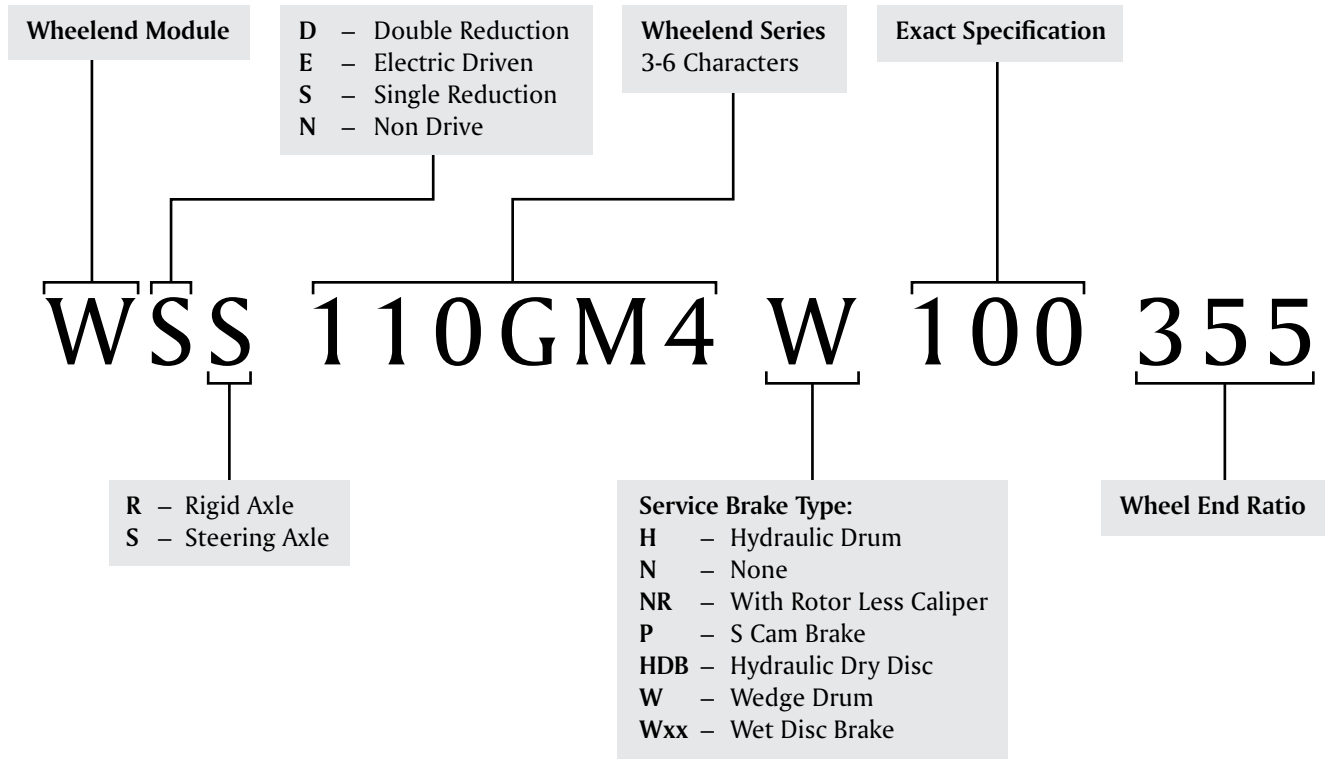

Examples:

WSS 110GM4 W 100 355 (100 mm Spindle, Large Planet Set, 4 Planet Gears)

WSR 90PM3 W 100 355 (90 mm Spindle, Small Planet Set, 3 Planet Gears)

WSR 2710 W3H 100 600 (Wheel End from 2710 Series Rigid Axle)

WSS 820 HDB 100 360 (Wheel End from 820 Series Steer Axle)

Planetary Axle Model Designations

Front Non-Drive Steer Axle

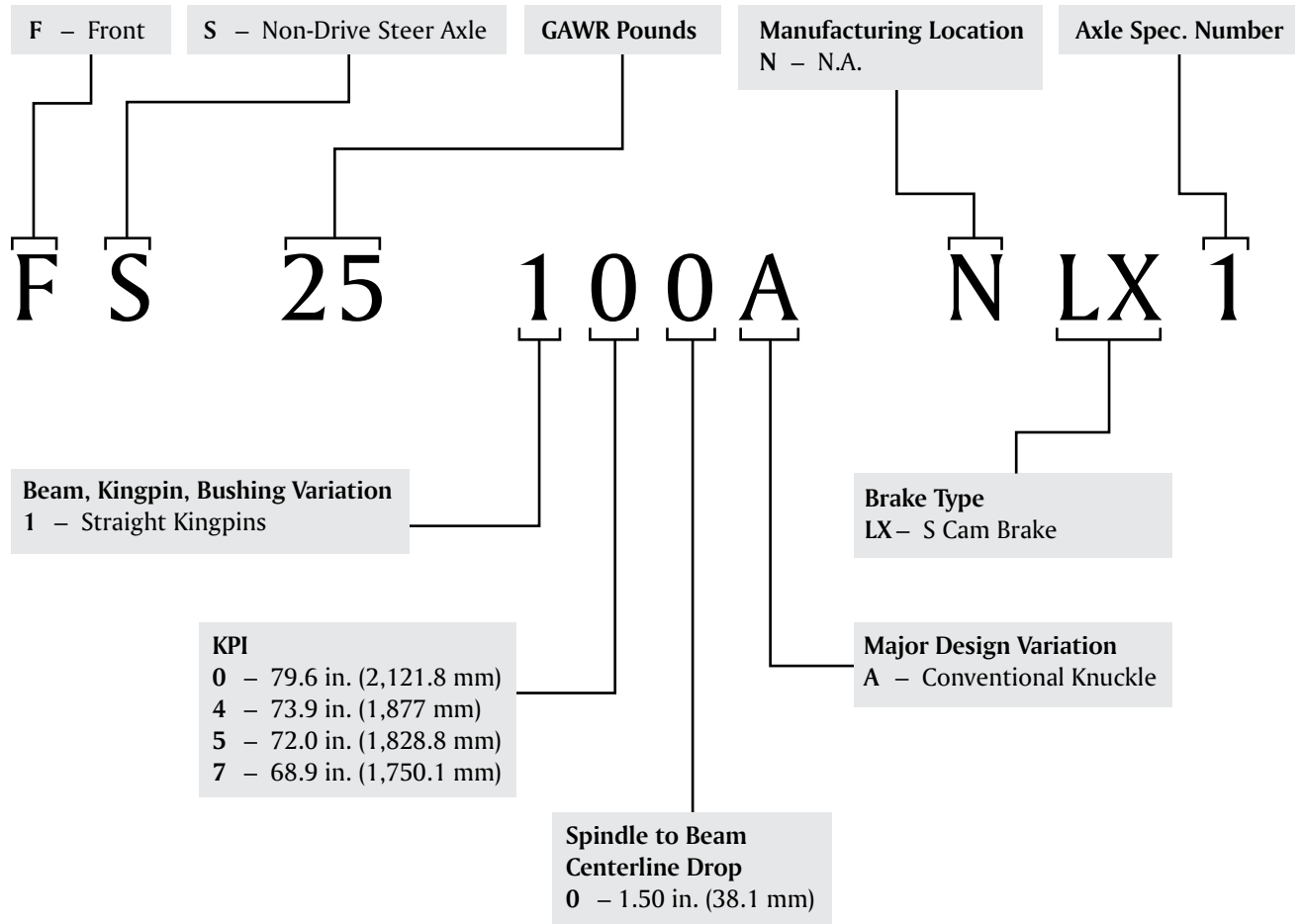

Example:
 FS25150ANLX2
 4002953b

AXLES

Planetary Axle Carrier Ratios

CARRIER ⁸											
	53500	A102	A104	F140	H140	H172	R155	RS120	RS145	RS160	RS186
RATIOS	3.58	2.26	2.05	4.63	5.83*	3.73	4.11	3.31	2.93♦	3.07	3.07
	4.11		2.92	5.29	6.17	4.63	5.29*	3.73	3.21	3.21	4.10
	4.71			7.80		5.29	6.17	4.30	3.42♦	3.42	4.56
	5.67					6.17		4.56	3.73	4.30	4.89
	5.86					6.83		4.88	3.90♦	4.56	5.13
	6.67					7.17		5.29	4.11♦	4.89	5.38
						7.80		5.86	4.33	5.38	5.63
						8.20		6.14	4.63	5.63	5.86
								6.83	4.88♦	6.14	6.14
								7.17	5.13		7.17
									5.29		
									5.57		
									5.86		
									6.14		
								6.83			
								7.17			
PREFERRED INPUT FLANGES											
2WCS		62N	62N	62N	62N	17N	16N	5WCS	17N	17N	
			72N	72N	72N	72N	72N	17N	72N	72N	
					85WB		62N	62N	85WB	85WB	
								72N	XS180	XS180	
								85WB			
OPTIONAL CARRIER MOUNTED PARKING BRAKES											
								A	B	C	

NOTE:

Preferred Ratio

A) 1270 SAHR 16.00" x .50" (406 x 13)

B) 1270 SAHR 19.32" x .50" (491 x 13)

C) 1270 SAHR 19.50" x .50" (495 x 13)

* Right Hand Gearing

** Ground Gears Available

*** Forward Tandem Carrier Ratios

♦ Right Hand and Left Hand Gearing Available

Refer to page 39 for footnotes.

Planetary Axle Carrier Ratios

CARRIER⁸										
RATIOS	PRA352	RS220	RS230	SQHP	SPR570	Series				
						3000	4000	5000 ⁷	4000DG* ^{***}	5000DG* ^{***}
	2.31	3.91/5.45	5.38/7.50	3.42	3.70	1.59	1.35**	1.35**	1.35	1.35
	2.85		6.50/9.07	3.55	4.11	1.67**	1.42	1.42	1.42	1.42
	3.70		7.17/10.0	3.90	4.33	1.69	1.46**	1.46**	1.50	1.50
	5.43			4.44		1.80	1.50	1.50	1.59	1.59
						1.84**	1.59**	1.59**	1.69	1.75
						1.93	1.69	1.69	1.75	1.69
						2.08	1.75	1.80	1.80	1.80
						2.25	1.80	1.93	1.93	1.93
					2.46	1.93	2.06**	2.08	2.08	
					3.18	2.06**	2.08	2.25	2.25	
					3.50	2.08	2.25		2.92	
					3.90	2.25	2.46		3.18	
					4.38	2.46	2.73			
					5.00		2.92			
							3.18			
							3.50			
							3.89			
							4.38			
							5.00			

PREFERRED INPUT FLANGES

	17N	17N	17N	18N	KV120	KV150	KV180	KV180	KV180
	72N	72N	72N	72N	KV150	17N	17N	17N	17N
	85WB	85WB	92N	92N		85WB	85WB	85WB	85WB

OPTIONAL CARRIER MOUNTED PARKING BRAKES

					YES	YES	YES		
--	--	--	--	--	-----	-----	-----	--	--

NOTE:

Preferred Ratio

Overall Axle Reduction =
 Carrier Ratio x Wheel End Reduction

Example:

Carrier Ratio = 7.20 : 1.0

Wheel End Ratio = 3.60 : 1.0

Overall Axle Reduction = 7.20 x 3.60 = 25.92 : 1.0

Differential Carrier Assembly Ratios:

SQHP Drop Box Ratios: .743
 1.00²⁵

SPR570 Drop Box Ratios: .756
 1.00

Overall Axle Reduction =
 Drop Box X Carrier Ratio X Wheel End Reduction

* Right Hand Gearing

** Ground Gears Available

*** Forward Tandem Carrier Ratios

Refer to page 39 for footnotes.

SUSPENSIONS AND MODULES

Independent Suspension Axle Systems (ISAS™)

Axle Model ²⁴	Typical Usage		Overall Axle Ratio Range	Differential Available	Planetary Ratio	Hub & Drum Inches (mm)
	Vehicle	lbs. (kg.) ²⁶				
3000 ISAS	Off-Highway Truck/ Armored Personnel Carrier	11,037(5,000)	5.6 - 17.7	Standard Limited Slip or Differential Lock	3.55	10 Stud - 13.19 BC (335)
4000 ISAS	4x4/6x6/8x8	17,000 (7,700)	3.9 - 28.0	Standard Limited Slip or Differential Lock	3.55	10 Stud - 13.19 BC (335)
	Off-Highway Truck/ Armored Security Vehicle/Personnel Carrier				4.28	10 Stud - 11.25 BC (285.75)
4000 ISAS Heavy Duty	4x4/6x6/8x8	19,000 (8,600)	4.8 - 28.0	Standard Limited Slip or Differential Lock	3.55	10 Stud - 13.19 BC (335)
	Off-Highway Truck/ Cargo Vehicle/Fuel Vehicle				4.63	
5000 ISAS	4x4/6x6/8x8/10x10	19,867 (9,000)	4.8 - 28.0	Standard Limited Slip or Differential Lock	3.55/4.00/4.63/5.6	10 Stud - 13.19 BC (335)
	Off-Highway Truck/ Cargo Vehicle and Airport Crash/Fire/Rescue	22,075 (10,000)				
5000 ISAS	4x4/6x6/8x8/10x10 Off-Highway Truck and Airport Crash/ Fire/Rescue	25,000 (11,500)	4.8 - 28.0	Standard Limited Slip or Differential Lock	3.55/4.00/4.63/5.6	10 Stud - 13.19 BC (335)

Wheelend Modules

Axle Model ²⁴	Typical Usage		Overall Axle Ratio Range	Differential Available	Planetary Ratio	Hub & Drum Inches (mm)
	Vehicle	lbs. (kg.) ²⁶				
4000 ²⁷	Off-Highway Truck/ Armored Personnel Carrier	12,000 - 19,000	N/A	N/A	3.22/3.55/4.28/5.6	10 Stud - 11.25 BC (285)
		(5,400 - 11,500)				10 Stud - 13.19 BC (335)
5000	Off-Highway Truck/ Armored Personnel Carrier	19,000 - 25,000 (8,600 - 11,500)	N/A	N/A	3.55/4.00/4.63/5.6	10 Stud - 13.19 BC (335)

Rigid Rear Axle/Suspension Tandem Modules

Axle Model ²⁴	Typical Usage		Overall Axle Ratio Range	Differential Available	Planetary Ratio	Hub & Drum Inches (mm)
	Vehicle	lbs. (kg.) ²⁶				
4000/5000	Off-Highway Truck/ Armored Personnel Carrier	40,000 - 60,000 (18,100 - 27,200)	4.8 - 28.0	Standard Limited Slip or Differential Lock	3.22/3.55/4.00/ 4.63/5.6	10 Stud - 11.25 BC (285) 10 Stud - 13.19 BC (335)

NOTE: When reading the tables above, consider the options in each column separately from adjacent rows. Items across rows do not necessarily relate to each other.

Refer to page 39 for footnotes.

Independent Suspension Axle Systems (ISAS™)

Brakes Inches (mm)	Minimum Rim Size Inches (mm)	Hub Flange To Flange Inches (mm)	Mounting Centers Inches (mm)	King Pin Intersection (KPI) Inches (mm)
14.5 x 1.2 (370 x 30) Hydraulic Disc Brake	19.5 (495)	78.38 (1,991)	According to OEM Requirements	53.0 (1,346)
15.0 x 5.0 (381 x 127) Wedge Brake 16.3 x 1.4 (415 x 36) Hydraulic Disc Brake 15.2 x 1.8 (385 x 45) Air Disc Brake	19.5 (495)	89.4 (2,270) 93.8 (2,383)	According to Truck Frame Width	62.8 (1,596) 64.96 (1,650)
15.0 x 5.0 (381 x 127) Wedge Drum Brake 15.2 x 1.8 (385 x 45) 17.1 x 1.8 (435 x 45) Air Disc Brake	19.5 (495)	89.8 (2,280) 93.7 (2,381)	According to Truck Frame Width	64.9 (1,650)
17.2 x 1.8 (436 x 45) Air Disc Brake 16.5 x 7 (420 x 178) 5 Cam Brake	20 (508)	91.4 (2,321)	According to Truck Frame Width	59.7 (1,517) 61.4 (1,561)
15.4 x 1.8 (392 x 45) 16.5 x 1.8 (420 x 45) Inboard Air Disc Brake	20 (508)	97.8 (2,484)	According to Truck Frame Width	69.5 (1,764)

Wheelend Modules

Brakes Inches (mm)	Minimum Rim Size Inches (mm)	Hub Flange To Flange Inches (mm)	Mounting Centers Inches (mm)	King Pin Intersection (KPI) Inches (mm)
12.6 x 1.3 (319 x 32) 16.3 x 1.4 (415 x 36) Hydraulic Disc Brake 15.0 x 5.0 (381 x 27) Wedge Brake	20 (508)	N/A	According to OEM Requirements	N/A
15.4 x 1.8 (392 x 45) Air Disc Brake 16.1 x 7.9 (410 x 200) Wedge Brake	20 (508)	N/A	According to OEM Requirements	N/A

Rigid Rear Axle/Suspension Tandem Modules

Brakes Inches (mm)	Minimum Rim Size Inches (mm)	Hub Flange To Flange Inches (mm)	Mounting Centers Inches (mm)	King Pin Intersection (KPI) Inches (mm)
16.5 x 7 (420 x 178) S Cam Brake	20 (508)	100.0 (2,452)	35.9 (912)	N/A

NOTE: When reading the tables above, consider the options in each column separately from adjacent rows.
Items across rows do not necessarily relate to each other.

Refer to page 39 for footnotes.

AXLES

Planetary Steer Axles

Description Axle Model ²³	Typical Usage ^{1,2}		Overall Axle Ratio Range	Differential Carrier Model ³	Planetary Ratio	Hub & Drum Inches (mm)
	Vehicle	lbs. (kg.) ²⁶				
3211SF	4x4 Off-Highway Truck	9,200 (4,200)	5.6 - 17.7	3000	3.55	8 Stud - 10.8 BC (275) 10 Stud - 13.19 BC (335)
3311SF	4x4 Off-Highway Truck	12,100 (5,500)	5.1 - 28.0	3000	3.22/3.55/5.6	8 Stud - 10.8 BC (275) 10 Stud - 13.19 BC (335)
4314SF	4x4 Off-Highway Truck	14,300 (6,500)	4.35 - 8.73	4000	3.22/3.55	8 Stud - 10.8 BC (275) 10 Stud - 13.19 BC (335)
4414SF/ 4414TF	4x4 Off-Highway Truck 6x6 Off-Highway Truck	17,600 (8,000) 17,600 (8,000)	4.8 - 8.73	4000/4000DG	3.55	10 Stud - 11.25 BC (285) 10 Stud - 13.19 BC (335)
4514SF	Truck	19,800 (9,000)	4.8 - 13.74	4000	3.55/4.0/4.63/5.6	10 Stud - 13.19 BC (335)
4414SF	Severe Duty 5G ²⁴	19,000 (8,636)	4.8 - 8.73	4000	3.55	10 Stud - 13.19 BC (335)
PSC205	Reach Truck Yard Crane Tow Tractor	20,000 (9,050) 16,000 (7,250) 17,500 (7,950)	10.9 - 25.8 15.29 - 28.0	RS120 F140	3.3/3.6	8 Stud - 15.0 BC (381)
5411SF/ 5411TF	6x6 Off-Highway Truck 8x8 Off-Highway Truck	21,000 (9,500)	4.8 - 8.73	5000/5000DG	3.55	10 Stud - 11.25 BC (285)
5513SF	RoRo Truck	22,000 (10,000)	4.8 - 28.0	5000	3.55/4.0/4.63/5.6	10 Stud - 13.19 BC (335)
5511SF/ 5511TF	6x6 Off-Highway Truck 8x8 Off-Highway Truck	22,000 (10,000) 26,500 (12,000)	4.8 - 28.0 6.3 - 28.0	5000/5000 DG	3.55/4.0/4.63/5.6	10 Stud - 13.19 BC (335)
5514SF/ 5514TF	Severe Duty 5G ²⁴	28,000 (12,700)	6.3 - 28.0	5000/5000 DG	3.55/4.0/4.63/5.6	10 Stud - 13.19 BC (335)
PSC822	Rough Terrain Crane Rough Terrain Excavator	25,000 (11,300) 24,000 (10,900)	11.9 - 25.8	RS120	3.6	12 Stud - 16.63 BC (422)
5512SF	All-Terrain Crane	28,700 (13,000)	7.6 - 28.0	5000/5000DG	5.6	10 Stud - 13.19 BC (335)

NOTE: When reading the tables above, consider the options in each column separately from adjacent rows. Items across rows do not necessarily relate to each other.

Refer to page 39 for footnotes.

Planetary Steer Axles

Brakes ⁵ Inches (mm)	Minimum Rim Size Inches (mm)	Hub Flange To Flange ⁴ Inches (mm)	Mounting Centers ⁴ Inches (mm)	King Pin Intersection (KPI) ⁴ Inches (mm)
14.6 x 1.18 HDB (370 x 30)	19.5 (495) 20 (508)	80.1 (2035)	29.7 (754)	57.6 (1464)
15.0 x 6.0 RSA (381 x 152)	19.5 (495)	73.0 (1,854)	24.0 (610)	48.8 (1,240)
DB 22LT ADB (Rotor = 16.2 (430))	20 (508)	83.2 (2,113)	32.3 (820)	59.0 (1,499)
15.9 x 1.18 HDB (405 x 30)		87.5 (2,223)	35.0 (890)	63.3 (1,609)
15.0 x 6.0 RDA (381 x 152)	20 (508)	73.0 (1,854)	24.0 (610)	48.8 (1,240)
DB 22LT ADB (Rotor = 16.2 (430))	19.5 (495)	83.2 (2,113)	32.3 (820)	59.0 (1,499)
15.9 x 1.18 HDB (405 x 30)		87.5 (2,223)	35.0 (890)	63.3 (1,609)
15.0 x 6.0 RDA (381 x 152)	20 (508)	83.2 (2,113)	32.3 (820)	59.0 (1,499)
16.5 x 6.0 S Cam (419 x 152)		87.1 (2,212)	33.0 (838)	62.9 (1,598)
DB 22LT ADB (Rotor = 16.2 (430))		91.9 (2,334)	34.5 (876)	67.7 (1,720)
15.9 x 1.18 HDB (405 x 30)				
16.1 x 7.9 RDA (410 x 200)	20 (508)	91.1 (2,314)	32.3 (820)	61.4 (1,560)
16.5 x 7.0 S Cam (419 X 178)		92.6 (2,352)	33.5 (850)	62.9 (1,598)
DB 22LT ADB (Rotor = 16.2 (430))		93.5 (2,374)		63.8 (1,620)
15.9 x 1.18 HDB (405 x 30)				
DB 22LT ADB (Rotor = 16.2 (430))	20 (508)	89.6 (2,276)	32.7 (831)	63.7 (1,620)
			33.0 (838)	70.5 (1,792)
			33.8 (860)	71.0 (1,804)
18.0 x .63 HDB (457 x 16)	24 (610)	85.5 (2,172)	42.0 (1,067)	64.1 (1,628)
16.5 x 7.0 S Cam (419 x 178)	20 (508)	93.5 (2,374)	33.5 (851)	63.8 (1,620)
16.1 x 7.9 RDA (410 x 200)				
DB 22LT ADB (Rotor = 16.2 (430))				
16.1 x 7.9 RDA (410 x 200)	20 (508)	93.5 (2,374)	32.3 (820)	63.8 (1,620)
DB 22LT ADB (Rotor = 16.2 (430))				
16.5 x 7.0 S Cam (419 x 178)	20 (508)	91.1 (2,314)	32.3 (820)	61.4 (1,560)
16.1 x 7.9 RDA (410 x 200)		92.6 (2,352)	33.5 (850)	62.9 (1,598)
DB 22LT ADB (Rotor = 16.2 (430))				
16.1 x 7.9 RDH (410 x 200)	20 (508)	98.1 (2,492)	35.8 (911)	68.5 (1,740)
18.5 x .63 HDB (470 x 16)	24 (610)	84.9 (2,155)	37.3 (947)	63.0 (1,600)
		83.5 (2,121)		
16.1 x 7.9 RDA (410 x 200)	24 (610)	92.6 (2,352)	KPI	62.9 (1,598)
DB 22LT ADB (Rotor = 16.2 (430))		101.1 (2,569)	(Hydrogas Suspension)	71.5 (1,815)

NOTE: When reading the tables above, consider the options in each column separately from adjacent rows.
Items across rows do not necessarily relate to each other.

Refer to page 39 for footnotes.

AXLES

Planetary Steer Axles

Description Axle Model ²³	Typical Usage ^{1,2}		Overall Axle Ratio Range	Differential Carrier Model ³	Planetary Ratio	Hub & Drum Inches (mm)
	Vehicle	lbs. (kg.) ²⁶				
PSTC824	Compactor	21,000 (9,500)	13.4 - 206.0 (PSTC and Upward)	H172	3.6/4.235	12 Stud - 16.63 BC (422)
PSC826	Rough Terrain Crane Snow Blower Off-Highway Exploration	37,000 (16,800) 26,000 (11,800) 27,000 (12,200)	10.5 - 30.4	RS145	3.6/4.235	12 Stud - 16.63 BC (422)
PSC1485	Tow Tractor Reach Truck	60,000 (27,200) 46,000 (20,800)	21.38 - 38.5	R155	5.2	22 Stud - 19.75 BC (502)
PSC1764	Rough Terrain Crane Reach Truck Log Loader	50,000 (22,700) 55,000 (24,950) 40,000 (18,100)	12.4 - 30.4	RS145	4.235	12 Stud - 16.63 BC (422) 23 Stud - 16.63 BC (422)
PSC1794	Rough Terrain Crane	58,000 (26,300)	15.2 - 37.3	RS145	5.2	24 Stud - 19.75 BC (502)
PSC5494	Rough Terrain Crane	90,000 (40,800)	16.0 - 31.9	RS160	5.2	24 Stud - 23.75 BC (603)

NOTE: When reading the tables above, consider the options in each column separately from adjacent rows. Items across rows do not necessarily relate to each other.

Refer to page 39 for footnotes.

Planetary Steer Axles

Brakes ⁵ Inches (mm)	Minimum Rim Size Inches (mm)	Hub Flange To Flange ⁴ Inches (mm)	Mounting Centers ⁴ Inches (mm)	King Pin Intersection (KPI) ⁴ Inches (mm)
20.25 x 4.0 RSA (514 x 102)	24 (610)	81.4 (2,068) 105.0 (2,667)	37.3 (947) 58.0 (1,473)	63.5 (1,613) 87.1 (2,212)
18.5 x .63 HDB (470 x 16) 20.25 x 5.0 S Cam (514 x 127)	24 (610) 25 (635)	84.9 (2,156) 86.7 (2,203) 100.7 (2,558)	37.3 (947)/38.0 (965) 38.0 (965) 43.0 (1,092)	63.0 (1,600) 64.9 (1,648) 78.9 (2,004)
18.75 x .44 HDB (476 x 11)	25 (635)	83.5 (2,121) 90.8 (2,306) 96.5 (2,451)	37.25 (946) 34.0 (864) 38.5 (978)	60.0 (1,524) 67.3 (1,709) 73.0 (1,854)
18.5 x .63 HDB (470 x 16)	25 (635)	100.9 (2,564)	38.5 (978)	77.5 (1,969)
18.5 x .63 HDB (470 x 16)	25 (635)	116.8 (2,967) 104.3 (2,649)	42.0 (1,067) 38.5 (978)	91.5 (2,324) 79.0 (2,007)
18.5 x 1.57 HDB (470 x 40)	29 (737)	116.3 (2,955)	44 (1,118)	75.4 (1,915)

NOTE: When reading the tables above, consider the options in each column separately from adjacent rows.
 Items across rows do not necessarily relate to each other.

Refer to page 39 for footnotes.

AXLES

Planetary Rigid Axles

Description Axle Model ²³	Typical Usage ^{1,2}		Overall Axle Ratio Range	Differential Carrier Model ³	Planetary Ratio
	Vehicle	lbs. (kg.) ²⁶			
3221SF	4x4 Off-Highway Truck	9,900 (4,500)	5.6 - 17.7	3000	3.55
3321SF	4x4 Off-Highway Truck	12,500 (5,700)	5.1 - 28.0	3000	3.22/3.55/5.6
4324SF	4x4 Off-Highway Truck	14,300 (6,500)	4.35 - 8.73	4000	3.22/3.55
PRC265	Special Vehicle Rail Car Mover	21,000 (9,500) 21,000 (9,500)	16.7 - 28.1	RS-120	3.6
4424SF	4x4 Off-Highway Truck	21,000 (9,500)	4.8 - 8.73	4000	3.55
4524SF	4x4 Off-Highway Truck	22,000 (10,000)	4.45 - 13.74	4000	3.3/3.55/4.0/4.63/5.6
PRLC124 ²⁵	Lift Truck	24,250 (11,000)	11.64	A102	5.143
5521SF	4x4 Off-Highway Truck	22,000 (10,000) 28,700 (13,000) 33,000 (15,000)	4.8 - 28.0 6.25 - 28.0 7.56 - 28.0	5000	3.55/4.0/4.63/5.6
5522SF	A.T. Crane	28,700 (13,000)	7.56 - 28.0	5000	5.6
PRLC144 ²⁵	Lift Truck	35,000 (15,900)	10.5 - 15.1	A104	5.143
5524SF/ 5524TF	RoRo AWD Terminal 4x4 Off-Highway Truck Tow Tractor Severe Duty 5G	55,100 (25,000) 35,300 (16,000) 28,700 (13,000) 30,000 (13,600)	7.56 - 28.0	5000 / 5000 DG	3.55/4.0/4.63/5.6
PRA/PROA352/ PRA/PROA382 ²⁵	Lift Truck Loader/Backhoe Loader Vibratory Roller	33,000 (15,000) 11,000 (5,000) 15,000 (6,800) 11,000 (5,000)	13.9 - 32.6	PRA 352 Series	6.0
PRC425	Lift Truck	66,100 (30,000)	10.5 - 25.8	RS145	3.6
PRC475	Lift Truck	66,100 (30,000)	10.5 - 25.8	RS145	3.6
PRC671	Harvester	21,000 (9,500)	11.9 - 25.8	RS120	3.6

NOTE: When reading the tables above, consider the options in each column separately from adjacent rows.
Items across rows do not necessarily relate to each other.

Refer to page 39 for footnotes.

Planetary Rigid Axles

Hub & Drum Inches (mm)	Brakes ⁵ Inches (mm)	Minimum Rim Size Inches (mm)	Hub Flange To Flange ⁴ Inches (mm)	Mounting Centers ⁴ Inches (mm)
8 Stud - 10.8 BC (275) 10 Stud - 13.19 BC (335)	14.6 x 1.18 HDB (370 x 30)	19.5 (495) 20 (508)	80 (2034)	37 (940)
8 Stud - 10.8 BC (275) 10 Stud - 13.19 BC (335) 15.9 x 1.18 HDB (405 x 30)	15.0 x 6.0 RSA (381 x 152) DB 22LT ADB (Rotor = 16.2 (430))	19.5 (495) 20 (508)	81.9 (2,080) 89.8 (2,280)	37.4 (950) 40.4 (1,025)
8 Stud - 10.8 BC (275) 10 Stud - 13.19 BC (335) 15.9 x 1.18 HDB (405 x 30)	15.0 x 7.0 RSA (381 x 178) DB 22LT ADB (Rotor = 16.2 (430))	20 (508)	86.2 (2,190)	39.4 (1,000)
8 Stud - 15.0 BC (381)	18.0 x .63 HDB (457 x 16) DB 22LT ADB (Rotor = 16.2 (430))	24 (610)	58.2 (1,478)	24.0 (610)
10 Stud - 11.25 BC (285) 10 Stud - 13.19 BC (335) 15.9 x 1.18 HDB (405 x 30)	16.5 x 6.0 S Cam (419 x 152) 15.0 x 7.0 RSA (381 x 178)	20 (508)	81.7 (2,075) 86.2 (2,190) 87.6 (2,226) 90.6 (2,300)	39.4 (1,000) 38.7 (983) 41.3 (1,050)
10 Stud - 13.19 BC (335) 15.9 x 1.18 HDB (405 x 30)	16.1 x 7.9 RDA (410 x 200) 16.5 x 7.0 S Cam (419 x 178) DB 22LT ADB (Rotor = 16.2 (430))	20 (508)	71.0 (1,803) 88.0 (2,235)	38.7 (983) 40.5 (1,029)
8 Stud - 10.8 BC (275)	9.0 W2H (229)	15 (381)	50.0 (1,270)	21.6 (549)
10 Stud - 13.19 BC (335)	16.1 x 7.9 RDA (410 x 200) 16.5 x 7.0 S Cam (419 x 178) 16.5 x 7.0 S Cam (419 x 178)	20 (508)	54.5 (1,385) 71.0 (1,803) 88.0 (2,235)	40.5 (1,029) 40.4 (1,025)
10 Stud - 13.19 BC (335)	16.1 x 7.9 RDA (410 x 200) 19.7 x 7.0 RDA (500 x 180)	20 (508) 24 (610)	92.6 (2,352)	KPI (Hydrogas Suspension)
8 Stud - 10.8 BC (275)	9.0 W2H (229)	15 (381)	61.4 (1,560)	29.1 (740)
10 Stud - 13.19 BC (335)	16.1 x 7.9 RDA (410 x 200) 16.5 x 7.0 S Cam (419 x 178) 15.7 x 4.7 H (400 x 120)	20 (508)	71.0 (1,803) 84.9 (2,156) 96.6 (2,455)	38.8 (986) 43.0 (1,092) 40.5 (1,028)
12 Stud - 8.75 BC (222) 16 Stud - 8 BC (203) 12 Stud - 15 BC (381) 8 Stud - 8 BC (203)	9.0 W2M (229) 9.0 W2H (229)	15 (381)	43.7 (1,110) 46.5 (1,181) 61.1 (1,552) 63.9 (1,623) 81.1 (2,057)	24.8 (629) 27.5 (699) 36.2 (920) 39.0 (991) None
10 Stud - 13.19 BC (335)	16.5 x 5.0 S Cam (419 x 127) 14.2 W3H (360)	20 (508)	72.6 (1,844) Q 67.0 (1,702) Q 71.1 (1,806) W3H/Q	40.0 (1,016) 38.0 (965) 40.0 (1,016)
10 Stud - 13.19 BC (335)	14.2 W3H (360)	20 (508)	71.1 (1,806)	40.0 (1,016)
12 Stud - 16.63 BC (422)	None	24 (610)	108 (2,743) 81.6 (2,072)	64.12 (1,629) 42.3 (1,074)

NOTE: When reading the tables above, consider the options in each column separately from adjacent rows.
Items across rows do not necessarily relate to each other.

Refer to page 39 for footnotes.

AXLES

Planetary Rigid Axles

Axle Model ²³	Description		Typical Usage ^{1, 2}		Overall Axle Ratio Range	Differential Carrier Model ³	Planetary Ratio
	Vehicle		lbs. (kg.) ²⁶				
PRC673	Special Purpose		22,800 (10,300)		10.5 - 25.8	RS145	3.6
	Loader		24,000 (10,900)				
	Tow Tractor		28,000 (12,700)				
	Fertilizer Spreader		31,000 (14,000)				
	Feller Buncher		16,000 (7,200)				
	Snow Blower		24,000 (10,900)				
PRC674	Fertilizer Spreader		31,000 (14,000)		14.0 - 19.6	RS220	3.6
PROC686	Feller Buncher		15,000 (6,810)		17.57 - 41.00	RS145	6.0
	Log Skidder		14,000 (6,360)				
PRC686	Feller Buncher		30,000 (13,630)		17.57 - 41.00	RS145	6.0
	Log Skidder		19,000 (8,630)				
PRC753	Transit Coach		26,000 (11,818)		4.8 - 5.66	4000	3.56
PRC727	Mining		43,000 (19,500)		12.4 - 30.4	RS145	4.235
PRC785	Lift Truck		75,000 (34,000)		10.5 - 25.8	RS145	3.55
			83,000 (37,650)				
PRLC874	Lift Truck (Solid Tire)		75,000 (34,000)		14.0 - 30.4	RS120	4.235

NOTE: When reading the tables above, consider the options in each column separately from adjacent rows. Items across rows do not necessarily relate to each other.

Refer to page 39 for footnotes.

Planetary Rigid Axles

Hub & Drum Inches (mm)	Brakes ⁵ Inches (mm)	Minimum Rim Size Inches (mm)	Hub Flange To Flange ⁴ Inches (mm)	Mounting Centers ⁴ Inches (mm)
12 Stud - 16.63 BC (422)	16.5 x 5.0 S Cam (419 x 127) 18.0 x .63 HDB (457 x 16)	24 (610)	83.4 (2,118) 93.5 (2,375) 96.1 (2,441)	45.0 (1,143) 40.8 (1,035) 40.8 (1,035)
12 Stud - 16.63 BC (422)	16.5 x 5.0 S Cam (419 x 127)	24 (610)	93.5 (2,375)	40.8 (1,036)
14 Hole - 12.00 BC (305)	None 14.2 W3H (360)	20 (508)	87.81 (2,230)	Trunnion
14 Hole - 12.00 BC (305)	14.2 W3H (360) None	20 (508)	87.81 (2,230)	43.1 (1,094)
10 Stud - 13.19 BC (335)	16.5 x 8.62 (419 x 219)	22.5 (572)	74.0 (1880)	37.0 (940)
24 Hole - 11.63 BC (295)	9.0 W2H (229)	20 (508)	95.4 (2,423)	44.0 (1,118)
10 Stud - 13.19 BC (335)	14.2 W3H (360) 16.5 x 7.0 S Cam (419 x 178)	20 (508)	73.9 (1,877) W3H 75.4 (1,915) P 97.5 (2,476) W3H 99.0 (2,515) P	40.0 (1,016)
20 Stud - 16.63 BC (422)	17.25 x 4.0 M (438 x 102) 14.2 W3H (360)	28 Solid Tire (711)	45.2 (1,148) 43.3 (1,099) 49.8 (1,264) 50.2 (1,275)	13.3 (338)

NOTE: When reading the tables above, consider the options in each column separately from adjacent rows. Items across rows do not necessarily relate to each other.

Refer to page 39 for footnotes.

AXLES

Planetary Rigid Axles

Description Axle Model ²³	Typical Usage ^{1,2}		Overall Axle Ratio Range	Differential Carrier Model ³	Planetary Ratio
	Vehicle	lbs. (kg.) ²⁶			
PRC1314	Mining Loader	37,500 (17,000)	15.2 - 37.3	RS145	5.2
PRLC1735	Railcar Mover Airport Refueler Truck Crane Log Handler Fertilizer Spreader	82,000 (37,200) 52,500 (23,800) 35,000 (15,900) 35,000 (15,900) 54,000 (24,500)	10.5 - 30.4	RS145	3.6/4.235
PRLC1752	Lift Truck (Solid Tire)	90,000 (40,800)	14.0 - 30.4	RS120	4.235
PRC1756	Lift Truck	110,000 (50,000)	12.4 - 28.9	RS145	4.235
PRLC1756	Lift Truck (Solid Tire)	100,000 (45,350)	12.4 - 30.4	RS145	4.235
PRLC1794	Lift Truck Empty Container Handler	130,000 (59,000) 130,000 (59,000)	15.2 - 37.3	RS145	5.2
PRLC1927	Heavy Hauler	55,000 (25,000)	10.5 - 21.0	RS160	3.43
PRLC2186	Dump Truck	68,500 (31,140)	10.5 - 21.0	RS160	3.43
PROC2715	Log Skidder Feller Buncher Loader	18,750 (8,523) 18,750 (8,523) 22,000 (10,000)	17.57 - 41.0	RS145	6.0
PRC2715	Log Skidder Feller Buncher Loader	37,500 (17,045) 37,500 (17,045) 44,000 (20,000)	17.57 - 41.0	RS145	6.0
PROC2725	Log Skidder Feller Buncher Loader	22,000 (10,000) 22,000 (10,000) 25,000 (11,300)	17.57 - 41.00	RS145	6.0
PRC2725	Log Skidder Feller Buncher Loader	44,000 (20,000) 44,000 (20,000) 50,000 (22,700)	17.57 - 41.00	RS145	6.0
PRC2726	Log Skidder Feller Buncher Loader	44,000 (20,000) 44,000 (20,000) 50,000 (22,727)	18.4 - 36.8	RS160	6.0

NOTE: When reading the tables above, consider the options in each column separately from adjacent rows. Items across rows do not necessarily relate to each other.

Refer to page 39 for footnotes.

Planetary Rigid Axles

Hub & Drum Inches (mm)	Brakes ⁵ Inches (mm)	Minimum Rim Size Inches (mm)	Hub Flange To Flange ⁴ Inches (mm)	Mounting Centers ⁴ Inches (mm)
23 Stud - 19.75 BC (502)	17.0 W4M (432)	25 (635)	56.3 (1,430)	23.3 (592)
10 Stud - 18.25 BC (464)	18.5 x .63 HDB (470 x 16)	24 (610)	59.8 (1,519)	29.4 (746)
12 Stud - 17.38 BC (441) (P)	20.25 x 7.0 S Cam (514 x 178)	73 x 44 (1,854 x 1,118)	96.2 (2,443) P	40.8 (1,036)
23 Stud - 16.63 BC (422) (HDB)	16.5 x 7.0 S Cam (419 x 178)		101.3 (2,574) HDB	42.5 (1,080)
12 Stud - 16.63 BC (422) (P)			98.5 (2,501) P	
			108.5 (2,755) P	
20 Stud - 16.63 BC (422)	20.25 x 5.0 S Cam (514 x 127)	36 Solid Tire (914)	50.5 (1,283)	13.3 (338)
12 Stud - 16.73 BC (425)	14.17 W3H (360)	24 (610)	81.29 (2,065)	39.8 (1,011)
			136.81 (3,475)	64.0 (1,626)
			127.95 (3,250)	
			147.87 (3,756)	
20 Stud - 16.63 BC (422)	20.25 x 5.0 S Cam (514 x 127)	36 Solid Tire (914)	50.4 (1,280)	15.3 (387)
22 Stud - 20.38 BC (518)	17.0 W4H (432)	24 (610)	95.6 (2,428)	None
21 Stud - 19.94 BC (506)				
12 Stud - 20.38 BC (518)	20.25 x 7.0 S Cam (514 x 178)	25 (635)	99.29 (2,522)	40.9 (1,039)
12 Stud - 20.38 BC (518)	20.25 x 7.0 S Cam (514 x 178)	25 (635)	99.29 (2,522)	40.9 (1,039)
18 Stud - 13.19 (335)	14.2 W3H (360)	20 (508)	98.1 (2,493)	None
18 Stud - 13.19 (335)	14.2 W3H (360)	20 (508)	98.1 (2,493)	34.4 (874)
				45.2 (1,148)
18 Stud - 13.19 (335)	14.2 W3H (360)	20 (508)	98.1 (2,493)	None
18 Stud - 13.19 (335)	14.2 W3H (360)	20 (508)	98.1 (2,493)	45.2 (1,148)
18 Stud - 13.19 (335)	14.2 W3H (360)	20 (508)	98.1 (2,493)	45.2 (1,148)

NOTE: When reading the tables above, consider the options in each column separately from adjacent rows. Items across rows do not necessarily relate to each other.

Refer to page 39 for footnotes.

AXLES

Planetary Rigid Axles

Axle Model ²³	Description	Typical Usage ^{1, 2}		Overall Axle Ratio Range	Differential Carrier Model ³	Planetary Ratio
	Vehicle	lbs. (kg.) ²⁶				
PRLC3804	Lift Truck (Solid Tire)	150,000 (68,000)		15.2 - 37.3	RS145	5.2
PRC3806	Lift Truck Log Loader	160,000 (72,600) 100,000 (45,400)		16.0 - 31.9	RS160	5.2
PRC5225	Loader	58,000 (26,300)		21.3 - 37.3	RS186	5.2
PRC7534	Lift Truck Container Handler Log Stacker	245,000 (111,100) 245,000 (111,100) 170,000 (77,100)		21.3 - 37.3	RS186	5.2

NOTE: When reading the tables above, consider the options in each column separately from adjacent rows. Items across rows do not necessarily relate to each other.

Refer to page 39 for footnotes.

Planetary Rigid Axles

Hub & Drum Inches (mm)	Brakes ⁵ Inches (mm)	Minimum Rim Size Inches (mm)	Hub Flange To Flange ⁴ Inches (mm)	Mounting Centers ⁴ Inches (mm)
23 Stud - 19.5 BC (495)	17.0 W4H (432)	25 (635)	88.1 (2,238)	15.3 (387)
24 Stud - 24.0 BC (610)		36 Solid Tire (914)	74.8 (1,900)	
23 Stud - 19.5 BC (495)	17.0 W4H (432)	25 (635)	96.0 (2,438) ⁹	43.0 (1,092)
24 Stud - 24.0 BC (610)		33 (838)		
23 Stud - 19.5 BC (495)	17.0 W4H (432)	25 (635)	91.0 (2,311)	40.0 (1,016)
	17.0 W4M (432)			
28 Stud - 19.5 BC (495)	17.0 W4H (432)	25 (635)	104.5 (2,654) ⁹	36.5 (927)
		33 (838)	105.9 (2,690) ⁹	36.5 (927)
			120.1 (3,051) ⁹	40.5 (1,029)

NOTE: When reading the tables above, consider the options in each column separately from adjacent rows. Items across rows do not necessarily relate to each other.

Refer to page 39 for footnotes.

AXLES

Planetary Tandem Axles

Description Axle Model ²³	Typical Usage ^{1,2}		Overall Axle Ratio Range	Differential Carrier ³ Model ⁶	Planetary Ratio
	Vehicle	lbs. (kg.) ²⁶			
4324TF/ 4324SF	6x6 Off-Highway Truck	28,600 (13,000)	4.8 - 8.7	4000DG/4000	3.55
4424TF/ 4424SF	6x6 Off-Highway Truck	42,000 (19,000)	4.8 - 8.7	4000DG/4000	3.55
4524TF/ 4524SF	6x6 Off-Highway Truck	48,500 (22,000)	4.8 - 13.74	4000DG/4000	3.55/4.0/4.63/5.6
5521TF/ 5521SF	6x6 Off-Highway Truck	57,300 (26,000) 53,000 (24,000)	4.8 - 17.8	5000DG/5000	3.55/4.0/4.63/5.6
5522TF/ 5522TB	Severe Duty 5G	53,000 (24,090)	4.8 - 17.8	5000DG/5000	3.55/4.0/4.63/5.6
SPRC673 ²⁵	Fertilizer Sprayer Geophysical	45,000 (20,400)	9.5 - 25.8 10.5 - 25.8	RT-145	3.6
5524TF/ 5524SF	6x6 Off-Highway Truck Severe Duty 5G	57,300 (26,000) 60,000 (27,215)	6.25 - 17.8	5000DG/5000	3.55/4.0/4.63/5.6
4524TF/ 4524BF	6x6 Off-Highway Truck	66,100 (30,000)	6.3 - 13.74 5.4 - 12.0	4000DG/4000	4.63/5.6
SPRC1735	Special Purpose Truck Crane Log Hauler	85,000 (38,600) 105,000 (47,600) 85,000 (38,600)	9.1 - 18.8 ²⁵	SQHP	3.6/4.235
SPRC1927	Log Hauler Articulated Hauler Truck Crane	110,000 (50,000) 115,000 (52,150) 120,000 (54,400)	9.6 - 19.0	SPR570	3.43/4.4
SPRC1937	Log Hauler Articulated Hauler Truck Crane	120,000 (54,545) 125,000 (56,818) 130,000 (59,091)	9.6 - 14.9	SPR570	3.43
SPRC2197	Log Hauler Truck Crane	136,000 (61,818) 140,000 (63,636)	9.6 - 14.9	SPR570	3.43
SPRC4806	Dump Truck Special Purpose Truck Crane Heavy Haul	138,000 (62,600) 150,000 (68,000) 180,000 (81,650) 180,000 (81,650)	12.9 - 19.9	SPR570	4.59

NOTE: When reading the tables above, consider the options in each column separately from adjacent rows. Items across rows do not necessarily relate to each other.

Refer to page 39 for footnotes.

Planetary Tandem Axles

Hub & Drum Inches (mm)	Brakes ⁵ Inches (mm)	Minimum Rim Size Inches (mm)	Hub Flange To Flange ⁴ Inches (mm)	Mounting Centers ⁴ Inches (mm)
8 Stud - 10.8 BC (275) 10 Stud - 13.19 BC (335)	15.0 x 7.0 RSA (381 x 178)	20 (508)	86.2 (2,190)	38.6 (980)
10 Stud - 11.25 BC (285) 10 Stud - 13.19 BC (335)	16.5 x 6.0 S Cam Plus (419 x 152) 15.0 x 7 RSA (381 x 178)	20 (508)	86.2 (2,335)	37.4 (950)
10 Stud - 13.19 (335)	16.1 x 7.9 RDA (410 x 200) 16.7 x 7.0 S Cam (424 x 178)	20 (508)	91.9 (2,335)	37.4 (950)
10 Stud - 13.19 BC (335)	16.5 x 7.0 S Cam (419 x 178) 16.1 x 7.9 RDA (410 x 200)	20 (508)	71.0 (1,803) ⁹ 91.9 (2,334) ⁹	37.4 (950) 40.5 (1,029)
10 Stud - 13.19 BC (335)	16.1 x 7.9 RDA (410 x 200)	20 (508)	96.6 (2,455)	47.0 (1,193)
12 Stud - 16.62 BC (422)	13.0 W3H (330) 16.5 x 5.0 S Cam (419 x 127)	24 (610) 24 (610)	90.0 (2,286) ⁹ 90.0 (2,286) ⁹	N/A N/A
10 Stud - 13.19 BC (335)	16.1 x 7.9 RDA (410 x 200) 16.5 x 7.0 S Cam (419 x 178)	20 (508)	94.2 (2,393) 108.6 (2,758) 96.6 (2,455)	44.9 (1,140) 40.5 (1,028)
10 Stud - 13.19 BC (335)	16.1 x 7.9 RDA (410 x 200) 16.5 x 7.0 S Cam (419 x 178)	20 (508)	71.0 (1,803)	38.7 (984)
12 Stud - 17.38 BC (441) 12 Stud - 21.38 BC (543)	16.5 x 7.0 S Cam (419 x 178) 20.25 x 7.0 S Cam (514 x 178)	20 (508) 24 (610)	85.0 (2,159) ⁹ 90.0 (2,286) ⁹ 100.0 (2,540) ⁹	41.5 (1,054) 36.5 (927) 41.5 (1,054) 36.5 (927) 56.5 (1,435)
12 Stud - 21.38 BC (543) 24 Stud - 21.38 BC (543)	20.25 x 7.0 S Cam (514 x 178) 17.0 W4H (432)	24 (610) 25 (635)	90.0 (2,286) ⁹ 100.0 (2,540) ⁹ 107.0 (2,718) ⁹	41.0 (1,041) 55.0 (1,397) 55.0 (1,397)
12 Stud - 21.38 BC (543)	20.25 x 7.0 S Cam (514 x 178)	24 (610)	90.0 (2,286) 100.0 (2,540)	41.0 (1,041) 55.0 (1,397)
12 Stud - 21.38 BC (543)	20.25 x 7.0 S Cam (514 x 178)	24 (610)	90.0 (2,286) 100.0 (2,540)	41.0 (1,041) 55.0 (1,397)
16 Stud - 19.5 BC (495)	20.25 x 7.0 S Cam (514 x 178)	24 (610)	105.5 (2,680) ⁹	45.3 (1,151)

NOTE: When reading the tables above, consider the options in each column separately from adjacent rows. Items across rows do not necessarily relate to each other.

Refer to page 39 for footnotes.

AXLES

Planetary Steer Tandem Axles

Description Axle Model ²³	Typical Usage ^{1,2}		Overall Axle Ratio Range	Differential Carrier ³ Model ⁶	Planetary Ratio
	Vehicle	lbs. (kg.) ²⁶			
4414SF/ 4414TF	6x6 Off-Highway Truck	35,300 (16,000)	4.8 - 8.73	4000/4000DG	3.55
5411SF/ 5411TF	8x8 Off-Highway Truck	41,900 (19,000)	4.8 - 8.73	5000/5000DG	3.55
5511TF/ 5511SF	8x8 Off-Highway Truck	44,100 (20,000)	4.8 - 28.0	5000DG/5000	3.55/4.0/4.63/5.6
5514TF/ 5514SF	8x8 Off-Highway Truck	60,000 (27,200)	7.56 - 28	5000DG/5000	4.63/5.6

Planetary Tridem Axles

Description Axle Model ²³	Typical Usage ^{1,2}		Overall Axle Ratio Range	Differential Carrier ³ Model ⁶	Planetary Ratio
	Vehicle	lbs. (kg.) ²⁶			
5521TF/ 5521TF/ 5521SF	Multi-Axle Off-Highway Truck	86,000 (39,000)	4.8 - 28.0	5000	3.55/4.0/4.63/5.6
EPRC1735	Truck Crane	125,000 (56,800)	9.1 - 19.5	SQHP	3.6/4.4

Portal Axles

Description Axle Model ²³	Typical Usage ^{1,2}		Overall Axle Ratio Range	Differential Carrier ³ Model ⁶	Planetary Ratio	Drop Inches (mm)
	Vehicle	lbs. (kg.) ²⁶				
3811SFD	4x4 Off-Highway Truck	7,840 (3,500)	5.62 - 8.685	3000	3.538	4.8 (123)
3821SFD	4x4 Off-Highway Truck	7,840 (3,500)	5.62 - 8.685	3000	3.538	4.8 (123)
4814SFD	4x4 Off-Highway Truck	9,900 (4,500)	4.78 - 8.68	4000	3.538	4.8 (123)
4824SFD	4x4 Off-Highway Truck	13,200 (6,000)	4.78 - 8.68	4000	3.538	4.8 (123)
4814SFW	4x4 Off-Highway Truck	15,500 (7,000)	4.3 - 7.9	4000	3.214	4.8 (123)
4824SFW	4x4 Off-Highway Truck	15,400 (7,000)	4.3 - 7.9	4000	3.214	4.8 (123)

NOTE: When reading the tables above, consider the options in each column separately from adjacent rows. Items across rows do not necessarily relate to each other.

Refer to page 39 for footnotes.

Planetary Steer Tandem Axles

Hub & Drum Inches (mm)	Brakes ⁵ Inches (mm)	Minimum Rim Size Inches (mm)	Hub Flange To Flange ⁴ Inches (mm)	Mounting Centers ⁴ Inches (mm)	King Pin Intersection
10 Stud - 11.25 BC (285)	15.0 x 6.0 RDA (381 x 152)	20 (508)	83.2 (2,113)	32.3 (820)	59.0 (1,499)
10 Stud - 13.19 BC (335)	16.5 x 6.0 S Cam (419 x 152)		87.1 (2,212)	33.0 (838)	62.9 (1,598)
			91.9 (2,334)	34.5 (876)	67.7 (1,720)
10 Stud - 11.25 BC (285)	16.5 x 7.0 S Cam (419 x 178) 16.1 x 7.9 RDA (410 x 200)	20 (508)	93.5 (2,374)	33.5 (851)	63.8 (1,620)
10 Stud - 13.19 BC (335)	16.5 x 7.0 S Cam (419 x 178) 15.0 x 6.0 RDA (381 x 152) 16.1 x 7.9 RDA (410 x 200)	20 (508)	91.1 (2,314)	32.3 (820)	61.4 (1,560)
10 Stud - 13.19 BC (335)	16.1 x 7.9 RDA (410 x 200) 16.5 x 7.0 S Cam (419 x 178) 19.7 x 7.0 RDA (500 x 180)	20 (508) 24 (610)	110.0 (2,794)	44.9 (1,140)	80.3 (2,040)

Planetary Tridem Axles

Hub & Drum Inches (mm)	Brakes ⁵ Inches (mm)	Minimum Rim Size Inches (mm)	Hub Flange To Flange ⁴ Inches (mm)	Mounting Centers ⁴ Inches (mm)
10 Stud - 13.19 BC (335)	16.5 x 7.0 S Cam (419 x 178) 16.1 x 7.9 RSA/RDA (410 x 200)	20 (508)	71.0 (1,803) ⁹ 91.9 (2,335) ⁹	35.4 (900)
12 Stud - 17.38 BC (441)	16.5 x 7.0 S Cam (419 x 178)	20 (508)	85.0 (2,159) ⁹	36.5 (927) 41.5 (1,054)
12 Stud - 21.38 BC (543)	20.25 x 7.0 S Cam (514 x 178)	24 (610)	90.0 (2,286) ⁹ 100.0 (2,540) ⁹	36.5 (927) 41.5 (1,054) 51.5 (1,308)

Portal Axles

Hub & Drum Inches (mm)	Brakes ⁵ Inches (mm)	Minimum Rim Size Inches (mm)	Hub Flange To Flange ⁴ Inches (mm)	Mounting Centers ⁴ Inches (mm)	King Pin Intersection (KPI) ⁴ Inches (mm)
8 Stud - 10.8 BC (275)	HDB (Rotor = 15.8 (403))	20 (508)	81.2 (2,064)	35.8 (910)	51.3 (1,304)
8 Stud - 10.8 BC (275)	HDB (Rotor = 15.8 (403))	20 (508)	79.6 (2,022)	36.7 (934)	None
8 Stud - 10.8 BC (275)	15.9 x 1.18 HDB (403 x 30)	20 (508)	81.2 (2,064)	35.8 (910)	51.3 (1,304)
8 Stud - 10.8 BC (275)	15.9 x 1.18 HDB (403 x 30)	20 (508)	79.6 (2,022)	36.7 (934)	None
10 Stud - 13.19 BC (335)	15.0 x 4.0 RSA (381 x 102)	20 (508)	89.4 (2,271)	33.0 (838)	59.0 (1,499)
10 Stud - 13.19 BC (335)	15.0 x 4.0 RSA (381 x 102)	20 (508)	89.8 (2,280)	41.1 (1,044)	None

NOTE: When reading the tables above, consider the options in each column separately from adjacent rows. Items across rows do not necessarily relate to each other.

Refer to page 39 for footnotes.

AXLES

T/A Series Axles

Description Axle Model ²³	Typical Usage ^{1,2}		Overall Axle Ratio Range	Differential Carrier Model ³	Planetary Ratio
	Vehicle	lbs. (kg.) ²⁶			
TA267	Tow Tractor	6,000 (2,700)	8.4 - 20.0	53500	None
TA268	Tow Tractor	10,000 (4,500)	11.8 - 22.0	53500	3.3

Jack Axles

Description Axle Model ²³	Typical Usage ^{1,2}		Overall Axle Ratio Range	Differential Carrier Model ³	Planetary Ratio
	Vehicle	lbs. (kg.)			
RS-JA-230	Pneumatic Roller	None	5.38 - 7.50 6.50 - 9.07 7.17 - 10.0	RS230	None

Non-Drive Steer Axles

Description Axle Model ²³	Typical Usage ^{1,2}		Overall Axle Ratio Range	Differential Carrier Model ³	Planetary Ratio
	Vehicle	lbs. (kg.) ²⁶			
5011F/ 5012F/ 5013F	Multi-Axle Vehicles	21,000 (9,500) 22,000 (10,000) 26,500 (12,000)	N/A	N/A	N/A
FS20	Truck Crane	20,000 (9,000)	N/A	N/A	N/A
FS25	Truck Crane Fertilizer Spreader	25,600 (11,600) 16,000 (7,250)	N/A	N/A	N/A

NOTE: When reading the tables above, consider the options in each column separately from adjacent rows. Items across rows do not necessarily relate to each other.

Refer to page 39 for footnotes.

T/A Series Axles

Hub & Drum Inches (mm)	Brakes ⁵ Inches (mm)	Minimum Rim Size Inches (mm)	Hub Flange To Flange ⁴ Inches (mm)	Mounting Centers ⁴ Inches (mm)
6 Stud - 7.25 BC (184)	12.5 x 1.02 HDB (318 x 26)	15 (381)	36.3 (922)	21.0 (533)
8 Stud - 6.50 BC (165)		16 (406)	47.0 (1,194)	28.3 (719)
		16.5 (419)	48.0 (1,219)	30.0 (762)
7 Stud - 13.31 BC (338)	12.5 x 2.25 DSH (318 x 57)	16 (406)	48.5 (1,232)	31.5 (800)
			47.2 (1,199)	28.0 (711)

Jack Axles

Hub & Drum Inches (mm)	Brakes ⁵ Inches (mm)	Minimum Rim Size Inches (mm)	Hub Flange To Flange ⁴ Inches (mm)	Mounting Centers ⁴ Inches (mm)
None	None	None	None	27.3 (693)

Non-Drive Steer Axles

Hub & Drum Inches (mm)	Brakes ⁵ Inches (mm)	Minimum Rim Size Inches (mm)	Hub Flange To Flange ⁴ Inches (mm)	Mounting Centers ⁴ Inches (mm)	King Pin Intersection
10 Stud - 11.25 BC (285)	16.1 x 7.9 RDA (410 x 200)	20 (508)	93.5 (2,374)	32.3 (820)	63.8 (1,620)
10 Stud - 13.19 BC (335)	19.7 x 7.1 RDA (500 x 180)	24 (610)	92.6 (2,352)	KPI (Hydrogas Suspension)	62.9 (1,598)
			101.1 (2,569)		71.5 (1,815)
10 Stud - 11.25 BC (285)	16.5 x 6 S Cam (419 x 152)	22.5 (572)	95.4 (2,423)	32.0 (813)	72.0 (1,829)
10 Stud - 13.19 BC (335)	16.5 x 7 S Cam (419 x 178)	22.5 (572)	95.6 (2,428)	32.0 (813)	72.0 (1,829)
10 Stud - 11.25 BC (285)	16.5 x 6 S Cam (419 x 152)		103.3 (2,623)	39.3 (997)	79.5 (2,020)

NOTE: When reading the tables above, consider the options in each column separately from adjacent rows. Items across rows do not necessarily relate to each other.

Refer to page 39 for footnotes.

TRANSFER CASES

Two-Speed

Description Model Series ^{13, 15, 23}	Oil Capacity Vertical Position ¹² Pints (Liters)	Typical Weight ^{1, 10} lbs. (kg.)	Output Location	Input to Output Drop Inches (mm)	Maximum Input Torque Rating by Ratio lbs.-ft. (N•m) ^{11, 23}	PTO
T-232 3-Shaft	Without P.D. 5.5 (2.5)	209 (94.8)	Front/Rear	8.74 (222)	1.95/1.0 2,580 (3,500)/2,580 (3,500)	Optional Full Power
	With P.D. 6.2 (2.9)	227 (103)			2.45/1.0 2,070 (2,800)/2,580 (3,500)	
					1.85/0.9 2,580 (3,500)/2,580 (3,500)	
					2.07/0.9 2,280 (3,100)/2,580 (3,500)	
T-600 3-Shaft	Without P.D. 7.81 (3.7)	342 (155.1)	Front/Rear	9.45 (240.0)	1.93/1.0 3,584 (4,860)/5,160 (7,000)	Optional Full Power
	With P.D. 9.51 (4.5)	374 (170)			2.45/1.0 2,950 (4,000)/5,160 (7,000)	

Single-Speed

Description Model Series ^{13, 15, 23}	Oil Capacity Vertical Position ¹² Pints (Liters)	Typical Weight ^{1, 10} lbs. (kg.)	Output Location	Input to Output Drop Inches (mm)	Maximum Input Torque Rating by Ratio lbs.-ft. (N•m) ^{11, 23}	PTO
T-600 3-Shaft	Without P.D. 7.81 (3.7)	342 (155.1)	Front/Rear	9.45 (240.0)	1.38:1.0 7,000 (9,500)	Optional
	With P.D. 9.51 (4.5)	374 (170)				

NOTE: When reading the tables above, consider the options in each column separately from adjacent rows. Items across rows do not necessarily relate to each other.

Refer to page 39 for footnotes.

Two-Speed

Park Brake	Oil Pump	Speedo Gears	Front Declutch	Airshift Proportional Differential	Integral Mounting Bosses	Airshift High/Low	Airshift Front Declutch	Synchronized Shift
Optional	Standard	Optional	Standard	Optional 32.4% Front/ 67.6% Rear	Standard	Standard	Standard	N/A
N/A	Standard	Optional	Standard	Optional 32.4% Front/ 67.6% Rear	Standard	Standard	Standard	N/A

Single-Speed

Park Brake	Oil Pump	Speedo Gears	Front Declutch	Airshift Proportional Differential	Integral Mounting Bosses	Airshift High/Low	Airshift Front Declutch	Synchronized Shift
N/A	Standard	Optional	Standard	Optional 32.4% Front/ 67.6% Rear	Standard	None	Standard	N/A

NOTE: When reading the tables above, consider the options in each column separately from adjacent rows. Items across rows do not necessarily relate to each other.

Refer to page 39 for footnotes.

BRAKES

Hydraulic Dry Disc Brakes

Model	Typical Usage	Disc Diameter and Thickness Range Inches (mm)	Maximum Pressure psi (bar)
	Vehicle		
HDB 4 x 76	Lift Truck	18.5 (470)	2,300 (159)
	Loader	16-25 Range (406 - 635)	Hydraulic
	Articulated Hauler	.63 (16)	
	Scraper	18 (457) Optimum .625 (16)	
HDB 6 x 76	Articulated Hauler	18.5 (470)	2,500 (172)
	Loader	1.58 (40)	Hydraulic

(IP) — Input Pressure

(DR) — Disc Radius

Park Brakes

Spring-Actuated Caliper Assembly

Model	Vehicle	Disc Diameter and Thickness Range Inches (mm)	Maximum Pressure psi (bar)
1270	On/Off-Highway (Transmission-Mounted)	10 - 23.6 (254 - 600) .5 (12.7)	2,610 (180)
1286 (RH) 1287 (LH)	On/Off-Highway (Transmission-Mounted)	10 - 23.6 (254 - 600) .5 (12.7)	3,000 (205)

(IP) — Input Pressure

(DR) — Disc Radius

NOTE: When reading the tables above, consider the options in each column separately from adjacent rows.
Items across rows do not necessarily relate to each other.

Refer to page 39 for footnotes.

Hydraulic Dry Disc Brakes

Wheel Rim Size Inches (mm)	Maximum Torque lb. in. (N•m)	Pistons Size Inches (mm)	Pistons Per Caliper	Lining Area Sq. Inches (Sq. mm)
25 (635)	IP x 10.18 x (DR - 1.5)	3 (76)	4	64 (41,280)
25 (635)		3 (76)	4	64 (41,280)
25 (635)	IP x 15.3 x (DR - 1.5)	3 (76)	6	89 (57,405)

(IP) — Input Pressure

(DR) — Disc Radius

Park Brakes

Spring-Actuated Caliper Assembly

Normal Mounting Position (o'clock)	Maximum Torque lb. in. (N•m)	Number of Pistons	Lining Area Sq. Inches (Sq. mm)
3, 9, or 12	22,127 - 61,070 (2,500 - 6,900)	1	6.5 (4,187)
3, 9, or 12	29,120 - 80,188 (3,290 - 9,060)	1	6.5 (4,187)

NOTE: When reading the tables above, consider the options in each column separately from adjacent rows.
Items across rows do not necessarily relate to each other.

Refer to page 39 for footnotes.

BRAKES

Hydraulic Wet Disc Brakes

Dura-Disc® Wet Disc Brakes — Integral with Axle

Model	Typical Usage	Size Inches (mm)	Maximum Number of Friction Plates ²³	Nominal Rated Brake Torque lb. in. (N•m)
	Vehicle			
W2H	Construction	9 (229)	10	120,000 (13,560) ¹⁸
	Material Handling			
W3H	Mining	14.2 (360)	3	198,000 (22,374)
	Construction	14.2 (360)	4	250,000 (28,250)
W4H	Mining	17 (432)	10	598,000 (67,574)
	Construction Material Handling			
W4M	Mining	17 (432)	6	365,000 (41,245)
	Construction			

Hydraulic Wet Disc Brakes

Dura-Disc® Wet Disc Brakes — Unit Mount

Model	Typical Usage	Size Inches (mm)	Maximum Number of Friction Plates	Maximum Rated Brake Torque lb. in. (N•m)
	Vehicle			
WDH330	Mining	13 (330)	6	175,000 (19,775)
	Construction	14.2 (360)	3	198,000 (22,374)
		14.2 (360)	4	250,000 (28,250)
WDH432	Mining	17 (432)	10	598,000 (67,574)
	Construction Material Handling			
WDM432	Mining	17 (432)	6	365,000 (41,425)

NOTE: When reading the tables above, consider the options in each column separately from adjacent rows. Items across rows do not necessarily relate to each other.

Refer to page 39 for footnotes.

Hydraulic Wet Disc Brakes

Dura-Disc® Wet Disc Brakes — Integral with Axle

Nominal Actuation Pressure ¹⁹ psi (bar)	Cooling Sump/Forced	Minimum Wheel ²⁰ Inches (mm)	Brake Function(s) ²¹	Brake Type
1,500 (103)	S, F	N/A	Serv/Sec	Shaft Speed
1,800 (124)	S, F	20 (508)	Serv/Sec	Wheel Speed
1,800 (124)	S, F	20 (508)	Serv/Sec	Wheel Speed
1,500 (103)	S, F	24 (610)	Serv/Sec	Wheel Speed
1,350 (93) ²²	S, F	24 (610)	Serv/Sec/Park	Wheel Speed, Spring Applied Hydraulic Release

Hydraulic Wet Disc Brakes

Dura-Disc® Wet Disc Brakes — Unit Mount

Nominal Actuation Pressure ¹⁹ psi (bar)	Cooling Sump/Forced	Minimum Wheel ²⁰ Inches (mm)	Brake Function(s) ²¹	Brake Type
1,500 (103)	S, F	20 (508)	Serv/Sec	Wheel Speed
1,800 (124)	S, F	20 (508)	Serv/Sec	Wheel Speed
1,500 (103)	S, F	24 (609.6)	Serv/Sec	Wheel Speed
1,350 (93) ²²	S, F	24 (609.6)	Serv/Sec/Park	Wheel Speed, Spring Applied Hydraulic Release

NOTE: When reading the tables above, consider the options in each column separately from adjacent rows. Items across rows do not necessarily relate to each other.

Refer to page 39 for footnotes.

BRAKES

Drum Brakes

Wedge Brakes

Brake Series	Actuation	Brake Diameters Inches (mm)	Brake Widths Inches (mm)	Brake Mounting	Brake Adjustment	Lining Attachment
RD	Dual Air / Hydraulic	15 (381)	5 (127)	Cast Spider	Automatic	Riveted
		16.1 (410)	6 (152) 7 (178) 7.9 (200)			
RS	Single Air / Hydraulic	15 (381)	5 (127)	Cast Spider	Automatic	Riveted
		16.1 (410)	6 (152) 7 (178) 7.9 (200)			

Drum Brakes

Cam Brakes

Brake Series	Actuation	Range of Brake Diameters Inches (mm)	Range of Brake Widths Inches (mm)	Brake Mounting	Brake Adjustment	Lining Attachment
S Cam	Air	16.5 (419)	5 (127)	Cast Spider	Automatic or Manual Slack Adjuster	Bonded and Riveted
		20.25 (514)	6 (152) 7 (178) 5 (127) 7 (178)			
S Cam	Air	15 and 16.5 (381 and 419)	4 (102)	Cast Spider	Automatic or Manual Slack Adjuster	Riveted
			5 (127) 6 (152) 7 (178) 8 (203) 8.63 (219) 10 (254)			

Refer to page 39 for footnotes.

FOOTNOTES

- 1 The axle/transfer case/brake torque guide-loadings indicated represent typical vocational values. Other vocations/ guide-loadings are possible for most axle series. Actual permitted ratings vary with type of vehicle and service and must be approved by our application engineering department. Individual installations must be approved by our product engineering department.
- 2 Guide-loadings may be lowered for deeper ratios in each model.
- 3 AxleTech International offers two types of carriers in a few axle models. Therefore, both types of carriers are indicated for reference. Note that overall axle ratio and carrier standout will vary with type of carrier installation.
- 4 Typical popular dimensions, such as hub flange-to-flange, track, axle mounting centers, and king pin intersections (steer axles) are indicated. Other combinations may also be available upon request.
- 5 Various brake options will affect indicated physical dimensions, such as flange-to-flange and track.
- 6 Some tandem/tridem carriers include optional input-mounted overdrive gear assemblies that are not reflected in carrier ratio charts but are included in the overall axle ratios indicated in the axle descriptions.
- 7 Not all ratios indicated in 5000 series single carriers are available in 5000 series tandem carriers confirm specific ratios with your AxleTech International representative.
- 8 Some ratios indicated are of low volume and may be classed as service level.
- 9 Track is indicated (where noted) in place of hub flange-to-flange dimensions.
- 10 Typical weights are indicated for basic configurations with common flanges and yokes (less lubricant).
- 11 Input torque ratings stated are for guide selection only and are calculated per AxleTech International published formulas. See note 23, below, for additional information.
- 12 Oil capacities indicated are for basic units. Additional oil recommendations are available dependent upon features and configurations required. Please contact your AxleTech International representative for specific lubrication recommendations.
- 13 When the transfer case is not equipped with a differential, the front axle declutch of transfer case must be disengaged for on-highway travel.
- 14 Two-speed transfer cases **MUST NOT BE ENGAGED IN RANGE SHIFT, DECLUTCH AND PTOs WHILE DRIVELINES ARE ROTATING. The vehicle MUST be stopped prior to shift engagement.**
- 15 SAHR: Spring Apply Hydraulic Release.
- 16 Static ratings based on burnished brakes.
- 17 Caliper assembly park brakes are spring applied and hydraulically released.
- 18 Multiply by wheel-end ratio to get torque at wheel.
- 19 Reference only; alternate pressures may be approved.
- 20 Depends on specific wheel rim being used.
- 21 Service/secondary; provides secondary function if vehicle system setup.
- 22 Hold-off pressure for spring applied hydraulic release brakes.
- 23
 - AxleTech International offers additional model options not indicated in this publication. Please contact your AxleTech International representative for your specific requirement.
 - All indicated typical usage guide-loadings are soft metric conversions.
 - In the instances where multiple wheel end ratios are available, not all wheel end ratios are applicable to indicated typical usage vocations/guide-loadings.
 - Variations in tire size, transmissions, engine power, torque, duty cycle and vocation affect application approvals.
 - AxleTech International's warranty applies only when components are used in approved applications.
- 24 High strength cardan available per specific application requirement.
- 25 Consult AxleTech representative for availability.
- 26 Nominal axle load rating as measured at the ground.
- 27 4000 Series wheelend modules are available with light weight components such as aluminum hubs, knuckles and brake calipers.

Locations

Manufacturing Facilities

Osasco, Brazil
 Oshkosh, Wisconsin, U.S.A.
 St. Etienne, France

TTT (Truck Trailer Transit)

Detroit, Michigan
 U.S. Gear
 Chicago, Illinois

Sales and Service Offices

Alcester, UK
 Ankara, Turkey
 Beijing, China
 Belvidere, Illinois, U.S.A.
 Boksburg, South Africa
 Chiba, Japan
 Manila, Philippines
 Mumbai, India
 Osasco, Brazil

Seoul, South Korea
 Singapore
 St. Etienne, France
 Sydney, Australia
 Taipei, Taiwan
 Troy, Michigan, U.S.A.
 Tokyo, Japan
 Tunis, Tunisia

- Manufacturing Facilities
- Sales and Service Offices



AxleTech International
 A GENERAL DYNAMICS COMPANY
 AxleTech International
 Suite 400
 3001 West Big Beaver Road
 Troy, Michigan 48084 USA
 1-877-877-9717
 Fax: 1-248-435-1990
 www.axletech.com

AxleTech International SAS
 4, Rue Jean Servanton
 Boite Postale 656
 42042 Saint Etienne Cédex 1
 FRANCE
 +33 477-92-88-00
 Fax: +33 477-92-88-93

AxleTech do Brasil Sistemas Automotivos Ltda.
 Av. Marechal Rondon, 840
 Osasco - SP - 06093-010
 BRASIL
 +55 11 3653-1420
 Fax: +55 11 3653-1424

AxleTech Belvidere Distribution Center
 795 Landmark Drive
 Belvidere, IL 61008 USA
 Distribution Center: 1-877-547-3907
 Fax: 1-866-547-3987
 Aftermarket Technical Support: 1-800-540-2794